

# Excitation and propagation of Electrostatic Ion Cyclotron waves in rf-sustained plasmas of interest to propulsion research

Rostislav Spektor\* and Edgar Y. Choueiri†

*Electric Propulsion and Plasma Dynamics Laboratory (EPPDyL)  
Mechanical and Aerospace Engineering Department  
Princeton University, Princeton, New Jersey 08544*

AIAA-2004-4095‡

July 11-14, 2004

Excitation and propagation of Electrostatic Ion Cyclotron (EIC) waves in an rf-sustained argon plasma are reported along with measurement of dispersion relation. Such waves can be used to energize the plasmas of a number of promising propulsion concepts. The waves are excited by an antenna consisting of two parallel metal plates inserted at the edge of a plasma column with their surface normal perpendicular to magnetic field. The plates can be driven in or out of phase. The in-phase configuration couples better to plasma. It is shown that EIC waves launched at frequencies between  $\omega_{ci}$  and  $10\omega_{ci}$  propagate with little damping at an angle between  $82^\circ$  and  $86^\circ$  with respect to the magnetic field. The amplitude of the excited waves can be optimized by properly matching the impedance of the driving circuit to the plasma and choosing the right plasma conditions. The dispersion relation was measured using a phase-delay technique and was found to be in good agreement with the theoretical EIC dispersion relation over a wide range of frequencies.

## I. INTRODUCTION

Inductive rf plasma sources, and in particular helicon plasma discharges, are of interest in propulsion research because of their high plasma production efficiency and controllability [1, 2]. Unfortunately, these rf plasma sources produce cold ( $T_i \sim 0.1$  eV) ions. To achieve high  $I_{sp}$  it is thus necessary to heat these ions considerably.

Various types of electrodeless plasma heating provide an efficient way to increase ion temperature. Methods such as the Ion Cyclotron Range Heating (ICRH), Lower Hybrid (LH) wave heating, and the current drive have been suggested for ion heating in fusion devices [3–5]. The ICRH scheme is also employed in the VASIMR experimental rocket concept [6–8]. In addition, ion heating by various electromagnetic and electrostatic instabilities has been observed in the Earth ionosphere [9–13].

In this article we investigate excitation of Electrostatic Ion Cyclotron (EIC) waves that propagate

transversely to the external magnetic field. Our previous theoretical and numerical studies have shown that two beating electrostatic waves, obeying specific criteria [14–17], may energize ions very efficiently. Such ion energization mechanism can prove to be useful in propulsion applications.

There is a lack of detailed measurements of EIC wave properties and propagation in rf-sustained plasmas. It is with this goal in mind that we investigate the excitation and propagation of EIC waves across a magnetized rf-sustained plasma column, and subsequent ion energization by these waves. In this paper we do not deal with ion energization but focus on the excitation and propagation of EIC waves.

This paper is organized as follows. In section II we review previous experimental work on electrostatic wave launching. Then in section III and IV we describe our experimental apparatus and the diagnostics used to detect and study the waves. In section V we analyze the electrostatic waves launched in our apparatus. We conclude with some final remarks in section VII.

## II. REVIEW OF PREVIOUS WORK

Various experiments reported on vigorous ion energization by EIC waves in magnetized plasmas.

\*Graduate Research Assistant. Member AIAA.

†Chief Scientist at EPPDyL. Associate Professor, Applied Physics Group. Associate Fellow AIAA.

‡Presented at the 40<sup>th</sup> AIAA/ASME/SAE/ASEE Joint Propulsion Conference

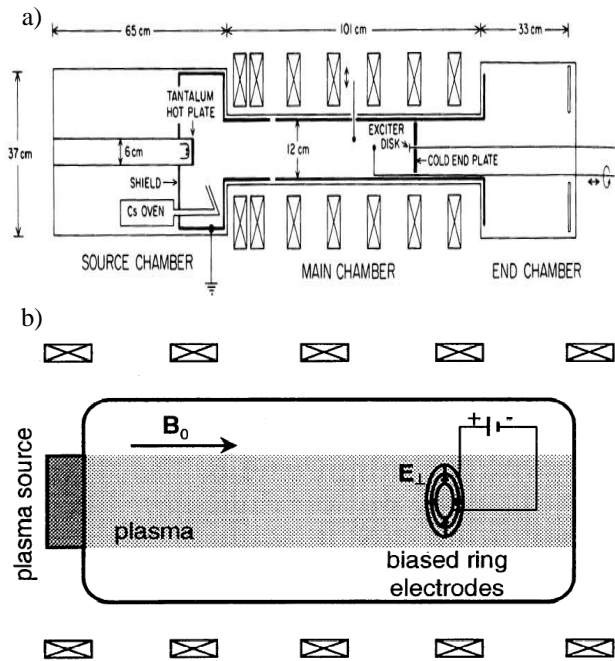

FIG. 1: Typical setup for studying Electrostatic Ion Cyclotron (EIC) wave. a) Used by Motley and D'Angelo [18] to excite current driven EIC. The picture is taken from Ref. [19]. b) Used by Koepke *et al.* to excite inhomogeneous energy density driven EIC. The picture is taken from Ref. [20].

However, most of these studies relied on exciting EIC waves through some internal plasma instability. Two typical experimental configurations are shown in Fig. 1.

In these experiments an electrostatic wave of frequency  $\sim \omega_{ci}$  is excited either by drawing electron current along the magnetic field to a positively biased small electrode, as shown in Fig. 1a, or by creating an electric field perpendicular to the external magnetic field, as shown in Fig. 1b. In both cases significant ion energization was observed once the wave was excited [19, 20]. Unfortunately in experiments like these, it is impossible to separate the cause from the effect - the ion energization from the wave generation mechanism. In addition the wave frequency cannot be controlled. Thus to investigate ion energization properly one needs to design an experiment where the waves are excited by some externally controlled antenna.

Four such antenna configurations are shown in Fig. 2. Hooke and Barnabei [21] used capacitively coupled plates, shown in Fig. 2a, and Stenzel and

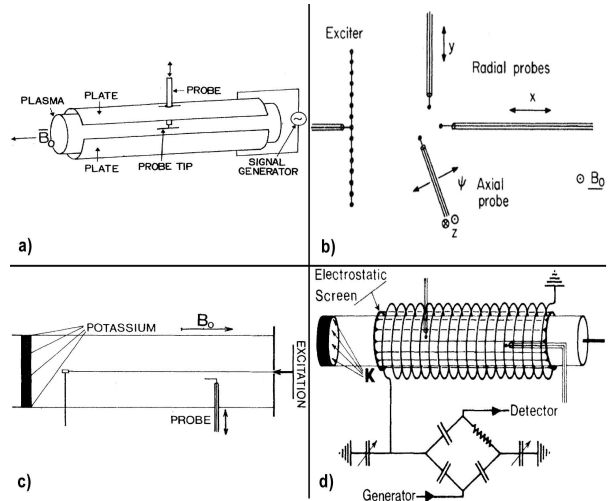

FIG. 2: Various antenna designs for launching waves into a plasma. a) Capacitively coupled plates, and b) a set of wires strung along the magnetic field launch waves close to the LH resonance. c) A single wire at the center of the plasma column, and d) a coil wrapped around the plasma column launch Bernstein waves.

Gekelman [22] employed a set of wires strung along the magnetic field, as shown in Fig. 2b, to launch waves close to the LH resonance. Schmitt launched Pure Ion Bernstein Waves (PIBW) with a single wire at the center of the plasma column [23], Fig. 2c, while Schmitt and Krumm launched Bernstein waves through a mode conversion mechanism with a wire coil wrapped around the plasma column [24], Fig. 2d.

Goree *et al.* [25] and Skiff *et al.* [26] used electrostatic plate antenna to launch a *single* electrostatic wave above the ion cyclotron frequency transversely to the magnetic field. Significant stochastic ion energization was reported in the latter experiment. Since our theoretical and numerical investigations have focused on similar frequency range we have adopted this antenna design for our experiment.

### III. EXPERIMENTAL SETUP

#### A. Vacuum Chamber

A schematic of the Beating Wave experimental apparatus (BWX) is shown in Fig. 3. It consists of two pyrex cylinders placed inside a 0.1 Tesla magnet. The axial magnetic field along the centerline is shown in Fig. 4. The two curves correspond to the

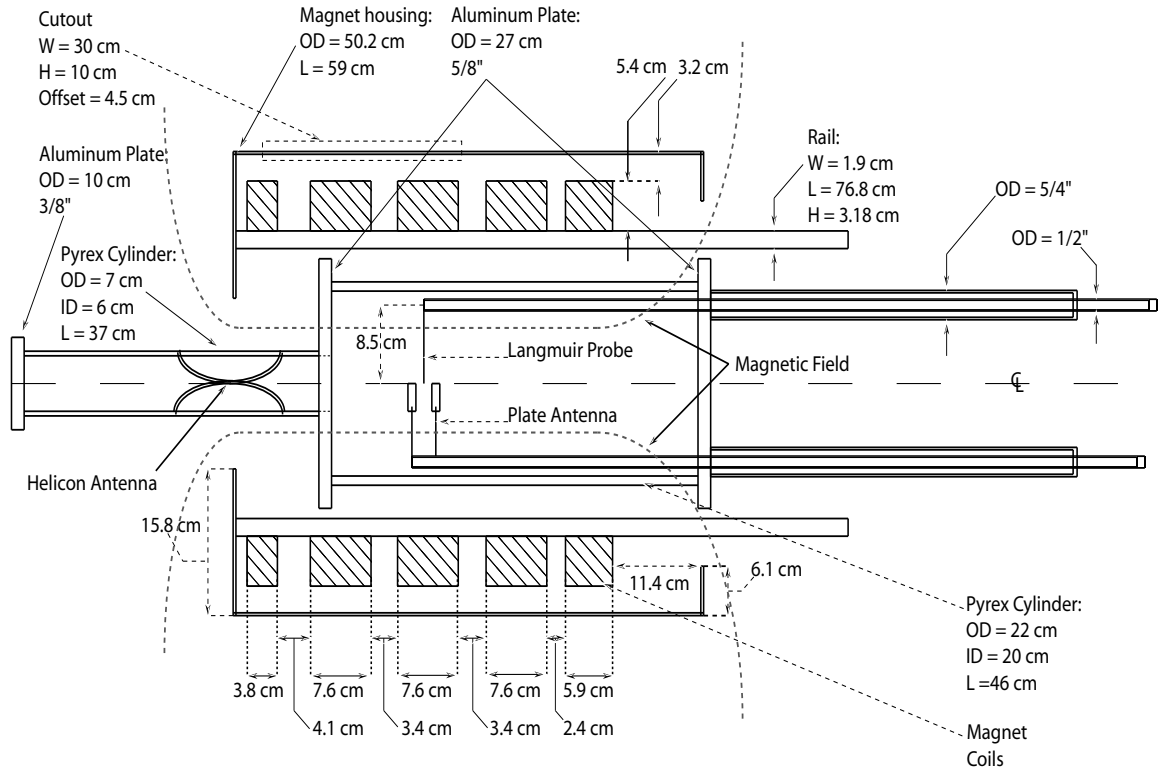
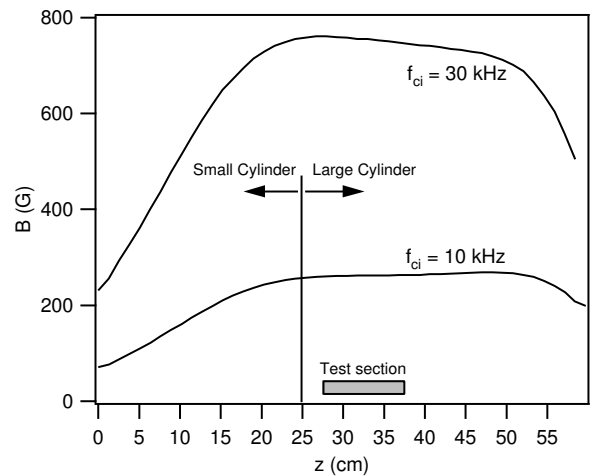

FIG. 3: The drawing of the BWX experimental apparatus.

ion cyclotron frequency of 10 kHz and 30 kHz in the test section of the vacuum chamber. The small cylinder is 6 cm in diameter (ID) and 37 cm in length while the large cylinder is 20 cm in diameter (ID) and 46 cm in length. The backplate of the small cylinder is made from molybdenum and is electrically floating to minimize sputtering. The two cylinders are connected by an electrically floating aluminum plate with a 6 cm concentric hole at the center to allow free flow of gas between the cylinders. A uniform fill pressure of 1 to 30 mTorr is maintained by a gas feed (Ar or He) at the aluminum endplate of the large cylinder and by a 150 l/s turbo pump with a conductance controller backed up by a roughing pump. The system is capable of maintaining a base pressure of  $2 \cdot 10^{-6}$  Torr.

Once the plasma discharge is ignited in the small cylinder, the plasma propagates along the magnetic field lines, which are parallel to the axis of the cylinders, into the large chamber where the wave-launching and plasma-energization experiments are conducted.

 FIG. 4: The axial magnetic field ( $B_z$ ) along the centerline of the magnet. The ion cyclotron frequency is relatively constant within the test portion of the large chamber where the electrostatic waves are launched.

## B. Plasma Source

A Boswell saddle type antenna used to create the plasma discharge is placed around the small cylinder. The antenna is made of 0.25" copper tubing

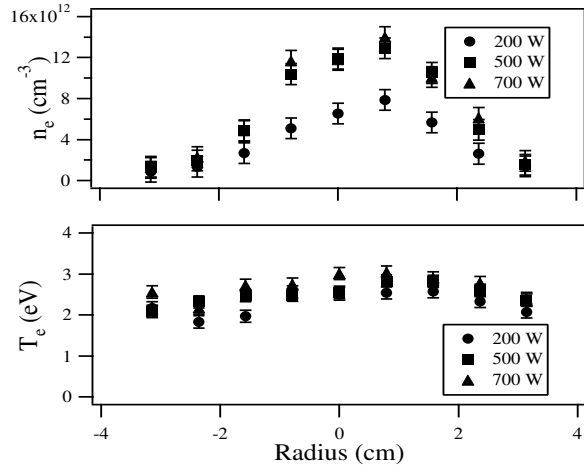

FIG. 5: Plasma density and electron temperature for various rf power to the saddle antenna. As rf power is raised above 500 W the high plasma density helicon discharge is observed.  $B=782$  Gauss,  $P=1\text{mTorr}$ .

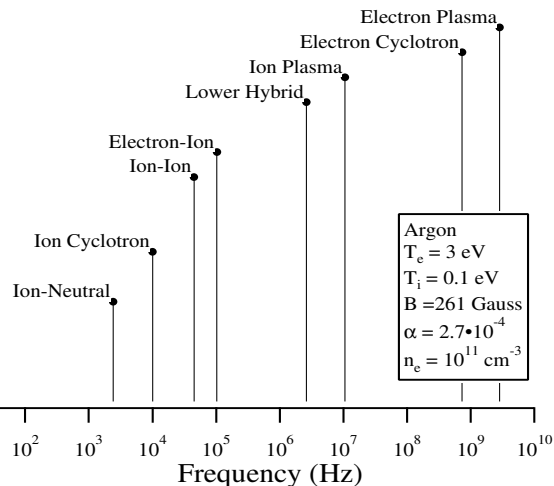

FIG. 6: Typical plasma parameters for the BWX experiment calculated with measured  $T_e, n_e$ .

to allow water cooling. An inductive discharge is produced by supplying rf power to the antenna from an ENI 13.56 MHz 1.2 kW power supply through a tuner. The tuner consists of an L network made of two Jennings 1000 pF 3 kV variable vacuum capacitors. The tuner is placed as close to the antenna as possible to maximize coupling.

An inductive discharge is easily obtained with only a few watts of forward rf power to the antenna and only a few percent of rf power reflected. A helicon discharge with high plasma density ( $10^{13} \text{ cm}^{-3}$ ) can be produced as rf power to the antenna is raised

above 500 W by properly adjusting the pressure and magnetic field. The inductively coupled discharge looks homogeneous and occupies the entire cross-section of the small cylinder. When the helicon discharge is obtained with argon, a bright blue column is observed at the centerline. Measured radial distributions of plasma density and electron temperature for both types of the discharges are shown in Fig. 5. Figure 6 shows the range of some natural plasma frequencies that were calculated with measured  $T_e, n_e$ , and  $B$ .

### C. Beating Waves Antenna

In attempt to launch electrostatic waves into the plasma column we have tried a couple of antenna configurations. An external antenna consisting of two spools of wire in the Helmholtz coil configuration, placed on opposite sides of the outside wall of the vessel, with their axis perpendicular to the magnetic field were initially used but did not excite electrostatic waves. The hope was that electromagnetic waves from this external antenna could be converted into electrostatic waves by the plasma [27, 28]. We were able to launch an electrostatic wave with an antenna placed inside the vacuum chamber, and consisting of two flat metal plates. This type of antenna has been used to launch a single electrostatic wave above the ion cyclotron frequency by Goree *et al.* in the toroidal ACT-1 device [25, 29], and by Skiff *et al.* in a linear device [26]. The antenna is made of two  $1 \text{ cm} \times 6 \text{ cm}$  molybdenum plates placed 3.14 cm apart along the magnetic field. The plates are oriented such that the long side and the surface normal are perpendicular to the magnetic field, as shown in Fig. 3. During the wave-launching experiments reported below, the plates were driven by a Wavetek 180 signal generator with a sinusoidal signal through a Tektronix AM 501 modular op-amp either in or out of phase, as shown in Fig. 7.

## IV. DIAGNOSTICS

Two types of Langmuir probes were employed to measure the steady-state plasma properties and the wave propagation. Plasma density and electron temperature were determined using a radio frequency compensated Langmuir probe with 0.5 mm graphite

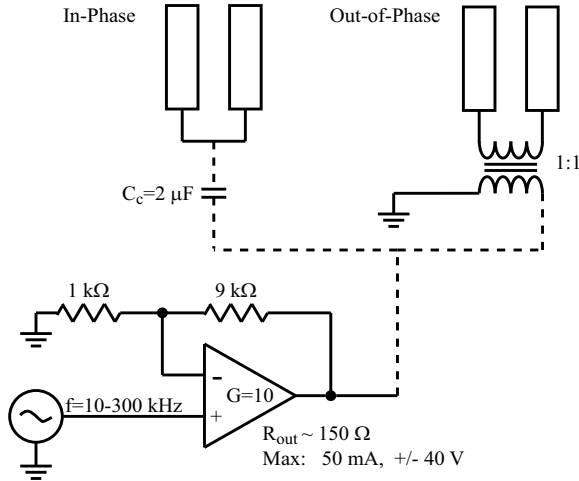

FIG. 7: The circuit diagram for launching a single electrostatic wave into the plasma column. The two antenna plates can be driven in or out of phase.

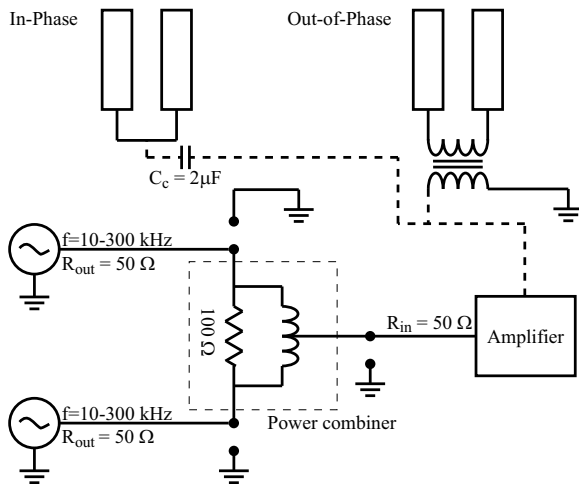

FIG. 8: To launch a pair of beating waves the impedance between the two signal sources and the amplifier has to be matched through a power combiner.

tip [30]. The rf compensation was achieved with four miniature inductors placed in series and close to the probe tip. The inductors were chosen to filter out the fundamental at 13.56 MHz and the second harmonic at 27.12 MHz of the helicon antenna signal. Uncompensated Langmuir probes with either graphite or T-shaped tips made of 10 mil tungsten wire were used to detect the wave and investigate its dispersion.

Instead of the Laframboise analysis [31] of the Langmuir probe I-V characteristic we used an empirical floating potential method specifically developed

by Chen *et al.* [32] to determine  $T_e$  and  $n_e$  with rf-compensated Langmuir probes in helicon-sustained plasmas similar to ours.

## V. WAVE LAUNCHING

The circuit used to launch a single electrostatic wave into the plasma column is shown in Fig. 7. The sinusoidal signal (10-300 kHz) from a Wavetek 180 signal generator is amplified with gain of 10 by a Tektronix AM 501 modular operational amplifier ( $R_{out} \sim 150 \Omega$ ,  $\pm 40$  V, 50 mA Max.). To drive the plates in phase the signal is sent to both plates. A coupling capacitor ( $C_c = 2 \mu\text{F}$ ) can be used, as indicated in Fig. 7, to allow both plates to float with respect to the plasma potential. To drive the plates out of phase the antenna is connected through a 1:1 transformer.

The launching of a pair of beating waves into the plasma is accomplished by combining the output from two signal sources. This is achieved by mixing the low-power signals coming out from two Wavetek signal generators and sending the combined output to an amplifier, as demonstrated in Fig. 8. The output impedance of the signal generators and the input impedance of the amplifier is  $50 \Omega$ . To make sure that the signal of one of the signal generators is not distorted by the other, we needed to match the impedance of the entire circuit. A power combiner consisting of a  $100 \Omega$  resistor and a tapped inductor in parallel provide good matching between the signal generators and the amplifier.

To ensure that the waves are launched into the plasma efficiently we also needed to maintain a good antenna-plasma coupling. Different amount of power is delivered to the antenna plates depending on the impedance mismatch between the driving antenna circuit and the plasma. Plasma impedance varies with the plasma density, i.e. with rf power delivered to the helicon antenna, and the fill-up pressure. For a given pressure the power to the antenna plates and the efficiency of the electrostatic wave launching can be correlated to the helicon antenna power.

In order to investigate the wave launching conditions we conducted the following experiment. The signal generator and the op-amp in Fig. 7 were set to produce a 30-Volt sinusoidal signal ( $\omega = 70$  kHz)

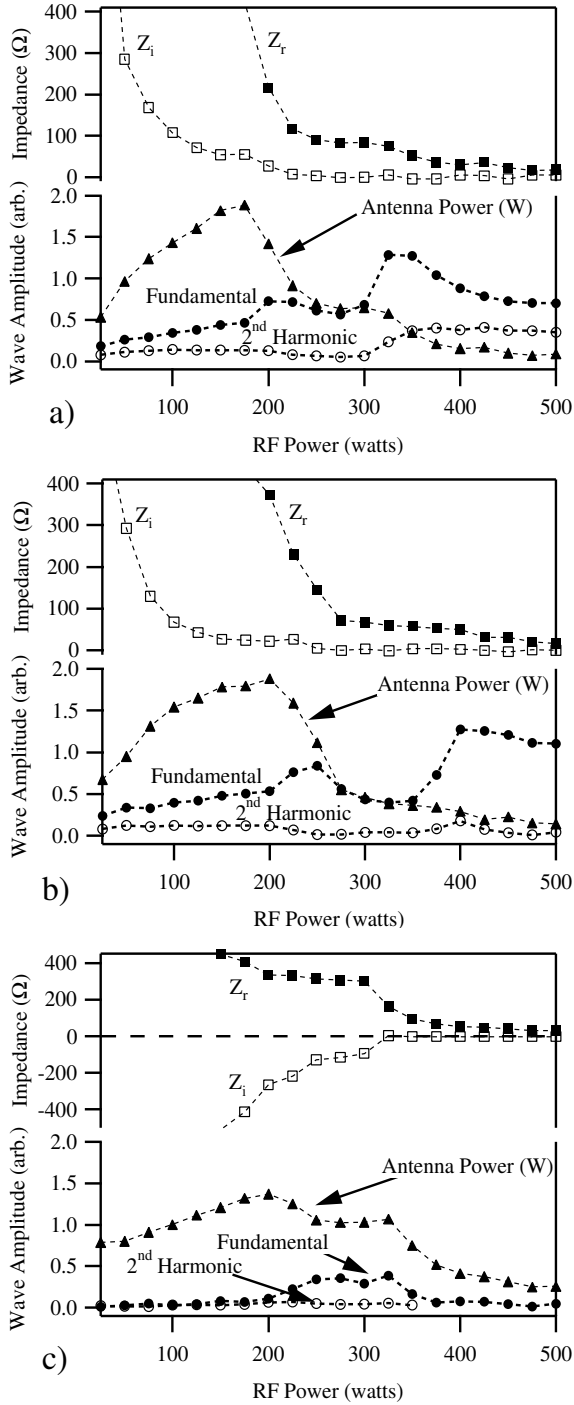

FIG. 9: The amplitude of the launched wave as well as the impedance and the power delivered to the antenna plates are shown as functions of the rf power to the helicon antenna. The real and imaginary components of the antenna impedance are designated by  $Z_r$  and  $Z_i$  respectively. The fundamental as well as the second harmonic of the launched waves are measured with a Langmuir probe. a) Both plates are driven in phase (without the coupling capacitor). b) Both plates are driven in phase (with a coupling capacitor connected in series with the antenna, Fig. 7). c) The plates are driven out of phase.

with no plasma. A magnetized argon plasma with  $n_e = 10^9 - 10^{13} \text{ cm}^{-3}$  and  $f_{ci} = 30 \text{ kHz}$  was produced by the helicon antenna with the chamber back filled to 1 mTorr. Measuring the plates voltage and current simultaneously we were able to determine the impedance and the power delivered to the antenna plates as a function of rf power delivered to the helicon antenna. A Langmuir probe inserted into the plasma column measured the amplitude of the launched waves.

We found that for the in-phase configuration the maximum power to the antenna plates is delivered when rf power is 175-200 W, as shown in Fig. 9a and 9b. The amplitude of the Langmuir probe signal is a complicated function of rf power, and it does not seem to track the power delivered to the antenna plates. There are two maxima for the detected wave amplitude. One occurs at 200 – 250 W of rf power, when the real component of the measured impedance ( $Z_r$ ) approaches 150 Ω, the output impedance of the op-amp, and the imaginary part ( $Z_i$ ) is small. At that condition the entire circuit is matched. The second, and higher maximum occurs at 350 – 400 W of rf power, and probably corresponds to the increase in plasma density due to the transition from the inductive discharge mode to the helicon mode. The real part of the measured impedance at that point is 50 Ω. A more efficient wave launching can thus be achieved by choosing an amplifier with an impedance close to that value.

It is interesting to note that the Langmuir probe detected a plasma wave at the second harmonic aside the fundamental frequency driven by the circuit. As shown in Fig. 9 the second harmonic can be a significant fraction of the fundamental.

A similar experiment was repeated with the antenna plates driven out of phase. The results are shown in Fig. 9c. The maximum power delivered to the antenna in this case is about 75% of the power in the case described above. Also, the wave amplitude detected by the Langmuir probe is significantly lower than the amplitude of the wave launched by the plates driven in phase. Possible reasons as to why the out-of-phase configuration does not couple well into the plasma will be given in the next section. However as in the previous case, the maximum in the wave amplitude corresponds to the matched circuit condition,  $Z_i \ll Z_r \sim 150 \text{ Ω}$ , and not to the maximum power delivered to the antenna plates.

The imaginary component of the impedance for the out-of-phase configuration is negative, indicating capacitive coupling between the plates. In the in-phase configuration the imaginary component is positive, indicating inductive coupling.

The in-phase driven antenna couples better to the plasma thus resulting in a wave with a higher amplitude than the out-of-phase driven antenna. We therefore undertook further study of the in-phase configuration. The goal of the study was to determine whether the launched wave is electrostatic in nature and whether it propagates transversely to the magnetic field.

## VI. DISPERSION RELATION MEASUREMENT

The electrostatic dispersion relation derived from the kinetic theory for an infinite slab of collisionless, homogeneous, isotropic, and non-drifting plasma can be written as [3, 25],

$$D = k_{\perp}^2 K_{xx} + k_{\parallel}^2 K_{zz} = 0, \quad (1)$$

where  $k_{\perp}$  and  $k_{\parallel}$  are the perpendicular and the parallel components of the wavenumber, and  $K_{xx}$  and  $K_{zz}$  are two components of the dielectric tensor. For a single ion species plasma these components can be expressed as,

$$K_{xx} = 1 + \frac{\omega_{pe}^2}{\omega_{ce}^2} + \frac{\omega_{pi}^2 e^{-\lambda_i}}{k_{\parallel} \omega \lambda_i} \left( \frac{m_i}{2T_i} \right)^{1/2} \times \sum_{n=-\infty}^{+\infty} n^2 I_n(\lambda_i) Z(\zeta_n^i), \quad (2a)$$

$$K_{zz} = 1 + \frac{2\omega_{pe}^2}{k_{\parallel}^2} \frac{m_e}{2T_e} \times \left[ 1 + \frac{\omega}{k_{\parallel}} \left( \frac{m_e}{2T_e} \right)^{1/2} Z(\zeta_0^e) \right], \quad (2b)$$

where  $I_n$  is the modified Bessel function,  $\lambda_j = k_{\perp}^2 T_j / m_j \omega_{cj}^2$ ,  $Z(\zeta_n^j)$  is the plasma dispersion function [33], and  $\zeta_n^j = (w - n\omega_j)(m_j/2T_j)^{1/2}/k_{\parallel}$ , with  $j = e, i$ . In Eqs. (2a) and (2b) we assumed that  $\omega \ll \Omega_e$  and  $\lambda_e \ll 1$ .

To launch an electrostatic ion cyclotron (EIC) wave above the ion cyclotron frequency the following conditions must also be satisfied [25],

$$\begin{aligned} \omega_{pi} &> \omega_{ci}, \quad T_i \lesssim T_e, \\ (2T_i/m_i)^{1/2} &\ll \omega/k_{\parallel} \ll (2T_e/m_e)^{1/2}. \end{aligned}$$

In our experiment we have  $T_e = 3$  eV,  $T_i = 0.1$  eV,  $B = 261$  Gauss,  $\omega = 30 - 180$  kHz, and  $\lambda_{\parallel} \approx 46$  cm, therefore the above inequalities are satisfied. Here we assumed that the parallel wavelength is determined by the extent of the large glass cylinder where the waves are launched. By measuring the parallel component of the wavenumber with two axially separated Langmuir probes we have confirmed that the parallel wavenumber is  $\sim 46$  cm. The numerical solution of Eq. (1) for the plasma parameters in our experiment is represented in Fig. 10.

Theoretical curves can be subdivided into two types according to their slopes. One curve extending from  $k_{\perp} = 0$  to  $2 \text{ cm}^{-1}$  has a positive slope. This curve represents the forward branch of the EIC dispersion relation since its group velocity ( $\partial\omega/\partial k$ ) is in the same direction as its phase velocity ( $\omega/k$ ). On the other hand, curves extending from  $k_{\perp} = 1$  to  $6 \text{ cm}^{-1}$  have negative slopes. The curves correspond to cyclotron harmonics of the backward branch of the EIC dispersion relation, since their group velocity has the opposite sign of the phase velocity. The pass-band of each of these backward branches is narrow, and therefore we do not expect to see any of the backward mode waves propagating in our experiment.

The slope of the forward branch of the EIC dispersion is sensitive to the electron temperature, while the backward branch is sensitive to the ion temperature. Thus comparing the experimentally obtained dispersion relation to the theoretical expression provides a good check of the species temperatures. While the ion temperature was not measured, the electron temperature inferred by the slope of the experimental dispersion relation,  $T_e = 2.75$  eV, is in good agreement with the values measured independently with the rf-compensated Langmuir probe, shown in Fig. 5.

As was mentioned above, the theoretical dispersion relation given by Eq. (1) was derived for an idealized plasma. Some plasma parameters of our experiment are given by Fig. 6. It can be seen that the plasma is collisional ( $\nu_{ei}, \nu_{ii} > f_{ci}$ ). Also, the density profiles shown in Fig. 5 indicate that the plasma is not homogeneous,  $(a/n)\partial n/\partial x \gtrsim 1$ , specifically at high rf power. Another point of concern is the effect of the plasma boundaries. At low values of  $k_{\perp}$  (long wavelength) the effect of the boundaries should be significant and the experimental data

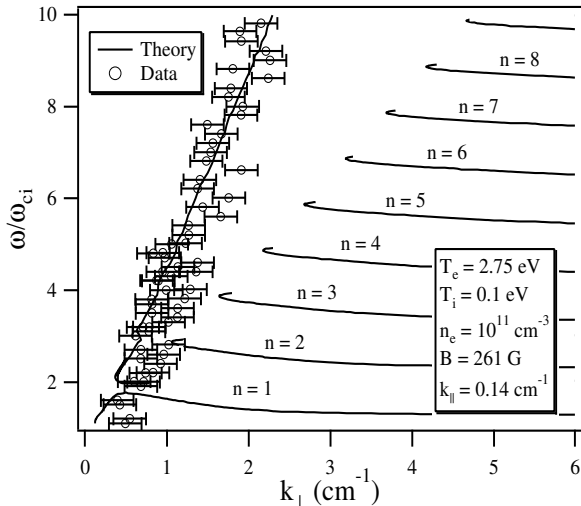

FIG. 10: The measured dispersion relation at  $f_{ci}=10$  kHz agrees well with the theoretical dispersion for the forward branch of the Electrostatic Ion Cyclotron wave (EIC). Curves extending to large values of  $k_{\perp}$  represent the cyclotron harmonics of the EIC backward branch.

might diverge from the theoretical expression. With these considerations in mind, Fig. 10 shows a surprisingly good agreement between the experiments and the theory for a wide range of frequencies. The experimental data were obtained in the following manner.

A single wave was launched by the antenna plates inserted at the edge of the plasma column and driven in the in-phase configuration. We measured the wave dispersion by a system of three uncompensated Langmuir probes. The probes were placed orthogonally to each other so that simultaneous measurements of  $k_{\perp}$  and  $k_{\parallel}$  could be performed by measuring the signal delay between any two probes [34]. Measuring the probe signal with the plasma discharge off we determined that the ac-coupling signal was two orders of magnitude below the wave signal with the plasma turned on.

The parallel component of the wavenumber measured by the two probes placed along the magnetic field indicated that the parallel wavelength of the wave is 46 cm - the length of the large glass cylinder. This measurement was confirmed by the wave observations at various axial positions along the chamber. The perpendicular wavenumber, shown in Fig. 10, varies in accordance with the EIC dispersion. The dispersion measurements indicate that the wave is propagating at the angle of  $82^{\circ}$  to  $86^{\circ}$  with re-

spect to the magnetic field. Both the fundamental and the second harmonic components of the signal were used to construct the experimental dispersion relation shown in Fig. 10.

Driving the plates of the antenna out of phase, we expected the parallel wavelength to be 6.28 cm – twice the spacing between the plates. This however was not the case. The measured parallel wavelength was on the order of the chamber length. The measurements of the perpendicular wavelength were not consistent with the EIC dispersion relation. It is likely that the wave was affected by the ion Landau damping since  $\omega/k_{\parallel} \sim v_{thi}$ .

## VII. CONCLUSIONS

We reported on the excitation and propagation of an Electrostatic Ion Cyclotron (EIC) wave launched by a two-plate antenna into a magnetized argon plasma. We described in detail the circuitry necessary to drive the antenna in the in- and out-of-phase configuration.

We found that the antenna driven in phase couples better to the plasma and excites higher amplitude waves than the plates driven out of phase.

In addition, we determined that the wave amplitude can be optimized by carefully choosing the right plasma parameters and building a matched driving circuit.

The antenna driven in phase excites a wave with  $\lambda_{\parallel} = 46$  cm - the length of the portion of the vacuum chamber where the waves are launched. The perpendicular component of the wavenumber varies according to the EIC dispersion relation and is in good agreement with the forward branch of the theoretical dispersion relation despite the simplifying assumption of a collisionless, magnetized, homogeneous, isotropic, and infinite plasma slab. We found that EIC waves launched at frequencies between  $\omega_{ci}$  and  $10\omega_{ci}$  propagate with little damping at an angle between  $82^{\circ}$  and  $86^{\circ}$  with respect to the magnetic field.

Multiple EIC waves required for our ongoing beating waves studies [14–17, 35] can also be easily launched by the plates antenna with two or more signal generators by means of a power combiner.

### Acknowledgements

This work has been carried out under contract from the US Air Force Office of Scientific Research (AFOSR). We also acknowledge support from the Plasma Science and Technology Program at the

Princeton Plasma Physics Laboratory. Mr. Robert Sorenson provided valuable assistance in developing the experiment. The authors are thankful to professor Scime of West Virginia University for equipment loaned.

- 
- [1] R. Boswell and F.F. Chen. Helicons - the past decade. *IEEE Trans. Plasma Sci.*, 25(6):1245, December 1997.
- [2] R. Boswell and F.F. Chen. Helicons - the early years. *IEEE Trans. Plasma Sci.*, 25(6):1229, December 1997.
- [3] T.H. Stix. *Waves in Plasmas*. Springer-Verlag, New York, 1992.
- [4] D.G. Swanson. *Plasma Waves*. Academic Press, Boston, 1989.
- [5] N. J. Fisch. Confining a tokamak plasma with rf-driven currents. *Phys.Rev. Lett.*, 41(13):873, September 1978.
- [6] E.A. Bering III, M. Brukhardt, F.R. Chang-Diaz, V. Jacobson J.P. Squire, R.D. Bengtson, J.N. Gibson, and T.Glover. Experimental studies of the exhaust plasma of the vasmr engine. Presented at the 40<sup>nd</sup> Aerospace Sciences Meeting, Reno, Nevada January ,14-17 2002, AIAA 2002-0345.
- [7] D.G. Chavers and F.R. Chang-Diaz. Momentum flux measuring instrument for neutral and charged particle flows. *Rev. Sci.Instrum*, 73(10):3500, October 2002.
- [8] F.R. Chang-Diaz, J.P. Squire, T.Glover, A.J. Petro, E.A. Bering III, F.W. Baity, R.H. Goulding, M.D. Carter, R.D. Bengtson, and B.N. Breizman. The vasmr engine: Project status and recent accomplishments. Presented at the 42<sup>nd</sup> Aerospace Sciences Meeting, Reno, Nevada January ,5-8 2004, AIAA 2004-0149.
- [9] E.G. Shelley, R.D. Sharp, and R.G. Johnson. Satellite observations of an ionospheric acceleration mechanism. *J. Geophys. Res.*, 3(11):654, 1976.
- [10] Mozer F.S., C.W. Carlson, M.K. Hudson, R.B. Torbert, B. Parady, and J. Yatteau. Observations of paired electrostatic shocks in the polar magnetosphere. *Phys. Rev. Lett.*, 38(6):292, 1977.
- [11] A.G. Ghielmetti, R.G. Johnson, R.D. Sharp, and E.G. Shelley. The latitudinal, diurnal, and altitudinal distributions of upward flowing energetic ions of ionospheric origin. *Geophys. Res. Lett.*, 5(1):59, 1978.
- [12] P.M. Kintner, M.C. Kelley, R.D. Sharp, A.G. Ghielmetti, M. Temerin, C. Cattell, P.F. Mizera, and J.F. Fennell. Simultaneous observations of energetic (keV) upstreaming and electrostatic hydrogen cyclotron waves. *J. Geophys. Res.*, 84(A12):7201, 1979.
- [13] P. Satyanarayana, P.K. Chaturvedi, M.J. Keskinen, J.D. Huba, and S.L. Ossakow. Theory of the current-driven ion cyclotron instability in the bottomside ionosphere. *J. Geophys. Res.*, 90(A12):12,209, 1985.
- [14] E.Y. Choueiri and R. Spektor. Coherent ion acceleration using two electrostatic waves. Presented at the 36<sup>th</sup> AIAA Joint Propulsion Conference, Huntsville, AL, July 16-20, 2000. AIAA-2000-3759.
- [15] R. Spektor and E.Y. Choueiri. Ion acceleration by beating electrostatic waves: Criteria for regular and stochastic acceleration. Presented at the 27<sup>th</sup> International Electric Propulsion Conference (IEPC), Pasadena, California October 14-19, 2001. IEPC-01-209.
- [16] R. Spektor and E.Y. Choueiri. Effects of ion collisions on ion acceleration by beating electrostatic waves. Presented at the 28<sup>th</sup> International Electric Propulsion Conference (IEPC), Toulouse, France March 17-21, 2003. IEPC-03-65.
- [17] R. Spektor and E.Y. Choueiri. Ion acceleration by beating electrostatic waves: Domain of allowed acceleration. *Phys.Rev.E*, 69(4):046402, April 2004.
- [18] R.W. Motley and N. D'Angelo. Excitation of electrostatic plasma oscillations near ion cyclotron frequency. *Phys. Fluids.*, 6(2):296, February 1963.
- [19] D.M. Suszcynsky, S.L. Cartier, R.L. Merline, and N. D'Angelo. A laboratory study of collisional electrostatic ion cyclotron waves. *J. Geophys. Res.*, 91(A12):13,729, December 1986.
- [20] D.N. Walker, , W.E. Amatucci, G. Ganguli, J.A. Antoniadis, J.H. Bowles, D. Duncan, V. Gavrischaka, and M.E. Koepke. Perpendicular ion heating by velocity-shear-driven waves. *Geoph.Res. Lett.*, 24(10):1187, May 1997.
- [21] W.M.Hooke and S.Bernabei. Direct observation of waves propagating near the lower-hybrid-resonance frequency. *Phys.Rev.Lett.*, 28(7):407, February 1972.
- [22] R.L.Stenzel and W.Gekelman. Electrostatic waves near the lower hybrid frequency. *Phys.Rev. A*, 11(6):2057, June 1975.

- [23] J.P.M. Schmitt. Dispersion and cyclotron damping of pure ion Bernstein waves. *Phys.Rev.Lett.*, 31(16):982, October 1973.
- [24] J.P.M. Schmitt and P. Krumm. Mode conversion and plasma column resonances in the ion-cyclotron harmonic range. *Phys.Rev.Lett.*, 37(12):753, September 1976.
- [25] J. Goree, M. Ono, and L. K. Wong. Observation of the backward electrostatic ion-cyclotron wave. *Phys. Fluids*, 28(9):2845, September 1985.
- [26] F. Skiff, F. Anderegg, and M.Q. Tran. Stochastic particle acceleration in an electrostatic wave. *Phys. Rev. Lett.*, 58(14):1430, April 1987.
- [27] J.L. Kline. Resonant ion heating in a helicon plasma. Ms, West Virginia University, 1998.
- [28] J. Kline, E. Scime, P.A. Keiter, M.M. Balkey, and R.F. Boivin. Ion heating in the helix helicon plasma source. *Phys.Plasmas*, 6(12):4767–4772, December 1999.
- [29] G.A. Goree. *The backward electrostatic ion-cyclotron wave, fast wave current drive, and fir laser scattering*. Ph.d, Princeton University, 1985.
- [30] R. Sudit and F. F. Chen. Rf compensated probes for high-density discharges. *Plasma Sources Sci. Technol*, 3:162–168, 1994.
- [31] J.G.Laframboise. Technical Report 100, University of Toronto, Institute for Aerospace Studies, 1966. Document No. AD634596.
- [32] F.F.Chen and J.D. Evans and D.Arnush. A floating potential method for measuring ion density. *Phys.Plasmas*, 9(4):1449, April 2002.
- [33] B.D. Fried and S.D. Conte. *The plasma dispersion function ; the Hilbert transform of the Gaussian*. Academic Press, New York, 1961.
- [34] D.E. Smith, E.J. Powers, and G.S. Cladwell. Fast-fourier-transform spectral-analysis techniques as a plasma fluctuation diagnostic tool. *IEEE Trans. Plasma Sci.*, PS-1:261, December 1974.
- [35] R. Spektor and E.Y. Choueiri. Design of an experiment for studying ion acceleration by beating waves. Presented at the 38<sup>th</sup> AIAA/ASME/SAE/ASEE Joint Propulsion Conference (JPC), Indianapolis, Indiana, July 7-10 , 2002.