

A Large Dielectric Vacuum Facility

ROBERT G. JAHN* AND KENN E. CLARK†
Princeton University, Princeton, N. J.

IN the experimental study and developmental testing of plasma propulsion devices of various types, interference of the vacuum chamber walls with the exhaust plume has proved to be a major limitation on simulation of space operation. This interference may take the form of an artificial constriction of the exhaust plume dimensions, of a recirculation of a portion of the ambient gas in the chamber through the plume, of a participation of the walls in the arc current conduction pattern, or of remote electromagnetic interactions between currents in the plume and induced currents in the walls. The first difficulty clearly relates to chamber size; the second relates to chamber size and to the ambient pressure that can be sustained during thruster operation. The remaining interactions are fostered by the electrical conductivity of the metallic walls of the conventional stainless steel or aluminum vacuum chambers. The desirable facility would thus seem to be a large, dielectric-walled vacuum vessel, capable of low ultimate pressure. Glass or quartz has the most desirable vacuum properties but is essentially unmanageable in the desired sizes. Plastic materials are structurally more convenient, but considerable uncertainty has surrounded their vacuum behavior for the large surface exposures involved in this application.

In connection with a program of pulsed plasma acceleration studies described in detail elsewhere,¹⁻³ design, construction, and testing of a 50-ft³ plastic vacuum tank was undertaken, as much to determine its actual vacuum capabilities as to provide a more satisfactory environment for experiments on the ejected plasma. Specifically, this is a vessel of 1-in.-thick Plexiglas G4 in the form of a cylinder 3 ft in diameter, 6 ft long, with a hemispherical fixed end and a dish-shaped removable end. Ports are provided for the plasma accelerator at the removable end and for exhaust sampling diagnostics at the fixed end. Each side of the tank also has four large access ports for pumping equipment, gages, diagnostic probes, and photographic flats. Figure 1 shows a sketch of this vessel.

The tank was fabricated at a nearby industrial shop§ in the following way. The main body of the vessel was formed by heating a 1-in.-thick plane sheet of Plexiglas to about 350°F and bending it over a half-cylinder mandrel, whereon it was

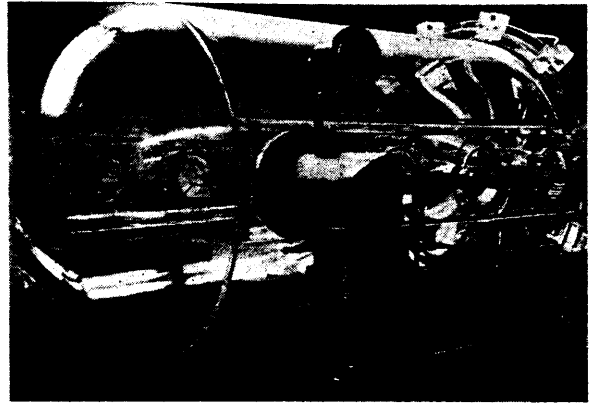

Fig. 2 Plexiglas vacuum facility.

allowed to cool uniformly and slowly. Two half-cylinders thus formed were trimmed, normalized, and chemically welded together by polymerizing in the joints a compound of methyl methacrylate monomer and polymer, a catalyst, and a promoter. The fixed hemispherical end was shaped in a "vacuum plug-assist" forming press from a similarly preheated 1-in. sheet of Plexiglas. After trimming and normalizing, it was welded onto the cylindrical member. The removable, dish-shaped end was free-formed in the same way. Two 1½-in.-thick strips of Plexiglas were fitted and cemented to the curvature of the cylinder over its entire length to serve as bosses for the four 6-in. ports on the side walls. These ports were provided with interchangeable Plexiglas covers of ½-in. plate. Figure 2 shows a photograph of the completed product, which cost approximately \$3800 in design, fabrication, and materials.

The tank is equipped with a 6-in. oil diffusion pump, a freon-cooled baffle, a 6-in. gate valve, and a 15-ft³/min fore-pump, which readily evacuate it to about 0.01 μ. At this pressure, the mean free path of the resident particles substantially exceeds the tank dimensions. The composition of the gas at this ultimate pressure has been analyzed with a "Diatron" mass spectrometer and found to be 89% water vapor, 6% nitrogen, 2% oxygen, and less than 1% each of carbon dioxide, argon, and all hydrocarbons. Thus, it appears that surface adsorption of water vapor, rather than Plexiglas sublimation, will be the essential limitation on the vacuum attainable in this device.

A pulsed plasma thruster operating at several kilojoules per pulse has been repeatedly discharged into this vessel with no observable change in the attainable vacuum or in the composition of the residual gas. After opening the tank to atmosphere, it can be returned to the stated level of operation by overnight pumping.

During the design, fabrication, and early application of this facility, there has been no indication of difficulty in scaling the device to substantially larger sizes. All elements of the present tank are heavily overdesigned from a structural standpoint, and the forming techniques just outlined can be extended to yet greater thicknesses. Use of plastic tanks for steady flow plasma devices clearly would require provision for vigorous cooling of the walls. However, although this material softens at much lower temperatures than the metals, it would seem that a double-walled vessel, or one generously wrapped with cooling coils, could still survive the thermal environment and retain a sufficiently low outgassing rate.

References

- 1 Jahn, R. G. and von Jaskowsky, W., "Structure of a large-radius pinch discharge," AIAA J. 1, 1809-1814 (1963).
- 2 Jahn, R. G. and von Jaskowsky, W., "Current distributions in large-radius pinch discharges," AIAA J. 2, 1749-1753 (1964).
- 3 Jahn, R. G., von Jaskowsky, W., and Burton, R. L., "Ejection of a pinched plasma from an axial orifice," AIAA J. 3, 1862-1866 (1965).

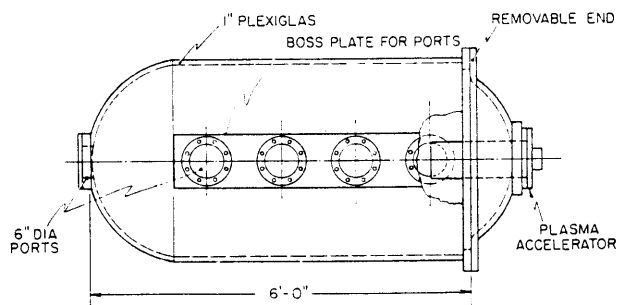

Fig. 1 Sketch of Plexiglas vacuum tank.

Received March 8, 1966. The authors gratefully acknowledge the contributions of A. R. Beach, H. E. Burkert, A. L. Casini, R. W. Culp, H. F. Edwards, T. J. Poli, and J. D. Tregurtha in the various stages of preparation of this unusual facility.

* Associate Professor of Aeronautical Engineering, Department of Aerospace and Mechanical Sciences. Associate Fellow Member AIAA.

† Graduate Fellow, Department of Aerospace and Mechanical Sciences. Student Member AIAA.

‡ Rohm and Haas Company, Bristol, Pa.

§ Edcraft Industries, Inc., Linden, N. J.